

# Clarke®



## PLASMA CUTTER

MODEL NO: PLASMA KING 25-SI

PART NO: 6015700

## OPERATION & MAINTENANCE INSTRUCTIONS



ORIGINAL INSTRUCTIONS

GC0922 Rev 3

---

## INTRODUCTION

---

Thank you for purchasing this CLARKE Plasma Cutter.

Before attempting to operate the machine it is essential that you read this manual thoroughly and carefully follow all instructions given. In doing so you will ensure the safety of yourself and that of others around you, and you can also look forward to the product giving you long and satisfactory service.

Ensure the machine suffered no damage during transit and that all components are present. Should any loss or damage be apparent, please contact your CLARKE dealer immediately.

---

## GUARANTEE

---

This CLARKE product is guaranteed against faulty manufacture for a period of 12 months from the date of purchase. Please keep your receipt as proof of purchase.

This guarantee is invalid if the product is found to have been abused or tampered with in any way, or not used for the purpose for which it was intended.

Faulty goods should be returned to their place of purchase, no product can be returned to us without prior permission.

This guarantee does not effect your statutory rights.

---

## ENVIRONMENTAL RECYCLING POLICY

---



Through purchase of this product, the customer is taking on the obligation to deal with the WEEE in accordance with the WEEE regulations in relation to the treatment, recycling & recovery and environmentally sound disposal of the WEEE.

In effect, this means that this product must not be disposed of with general household waste. It must be disposed of according to the laws governing Waste Electrical and Electronic Equipment (WEEE) at a recognised disposal facility.

If disposing of this product or any damaged components, do not dispose of with general waste. This product contains valuable raw materials. Metal products should be taken to your local civic amenity site for recycling of metal products.

---

## SAFETY AND GENERAL WARNINGS

---



CAUTION: IF DURING THE CUTTING OPERATION A SLIGHT ELECTRIC SHOCK IS FELT, STOP WORK IMMEDIATELY AND DO NOT USE THE UNIT UNTIL THE FAULT HAS BEEN DISCOVERED AND RESOLVED.

---

1. Make sure that the unit is earthed and that the supply line has an adequate earth connection.
2. Make sure that any workbench used has a satisfactory earth connection.
3. Avoid contact between the metal being cut and bare skin or damp clothes.
4. **DO NOT** lean on the workpiece being cut or hold it in your hands.
5. **DO NOT** use in a damp environment or on wet surfaces.
6. **DO NOT** use the unit if the torch or cables appear damaged.
7. **ALWAYS** turn the unit off before replacing the electrode, the nozzle or the spreader tip of the torch.
8. **DO NOT** allow debris to collect as this could obstruct air flow to the machine.
9. **ALWAYS** switch the unit off and remove the power cable from the mains socket before carrying out any maintenance on the unit.
10. All the panels of the unit should be correctly closed after carrying out maintenance.

## HARMFUL FUMES AND GASES

---



CAUTION: WHEN HALOGENATED SOLVENTS OR DEGREASING AGENTS ARE PRESENT, THE MATERIAL TO BE CUT SHOULD BE CLEANED PROPERLY TO PREVENT THE FORMATION OF TOXIC GASES. SOME CHLORINATED SOLVENTS MAY DECOMPOSE IN THE PRESENCE OF THE RADIATION GIVEN OUT BY THE ARC AND MAY GENERATE PHOSGENE GAS.<sup>7</sup>

---

Harmful fumes and metallic powders are produced during the cutting operation. Metals which are painted or coated or which contain mercury, cadmium, zinc, lead and graphite may produce harmful concentrations of toxic fumes during cutting. To protect the operator or other persons from exposure to possible toxic fumes, fume respirators should be worn and work areas should be adequately ventilated.

When working in enclosed environments, suction units should be fitted below the cutting areas.

## **FIRE HAZARDS**

---



CAUTION: DO NOT CUT FUEL OR LUBRICANT CONTAINERS EVEN IF THEY ARE EMPTY. DO NOT CUT CONTAINERS OR CASINGS WHICH CONTAIN FLAMMABLE MATERIAL. NEVER CUT IN ENVIRONMENTS WHICH ARE POLLUTED BY FLAMMABLE GAS OR COMBUSTIBLE LIQUID VAPOURS (SUCH AS PETROL).

---

1. Prevent sparks or hot scale from producing flames.
2. Remove inflammable or combustible materials from the cutting area.
3. Make sure that fire-fighting equipment is located near the work area.
4. Situate the unit in an area where the air can be sucked in and exhausted from the grilles on the panel.

## **ELECTRO-MAGNETIC INTERFERENCE (EMI)**

1. Make sure that there are no other power supply cables, control lines, telephone leads or other equipment near the unit.
2. Make sure that there are no radio receivers or televisions.
3. Make sure there are no computers or other control systems.
4. Make sure that there is no-one with a pacemaker or hearing aid in the area around the unit.
5. Check the immunity of any other equipment operating in the same environment. In certain cases additional protective measures may be required. Before installing the plasma cutting unit, carry out an inspection of the surrounding area, observing the following guidelines:

Interference can be reduced in the following ways:

1. If there is interference in the power supply line, an E.M.I. filter should be inserted between the mains and the unit.
2. The output cables of the unit should be shortened; these should be kept close together and stretched along the ground.

---

## **PERSONAL PROTECTIVE EQUIPMENT(PPE)**

---

One of the hazards during the cutting process is the emission of electromagnetic waves due to the electric arc. The length of these waves ranges from infrared to ultraviolet. If these rays hit the eyes they can cause various complaints such as conjunctivitis, burns to the retina, deterioration of sight, etc. Moreover a high concentration of ultraviolet rays can burn the skin. It is, therefore, extremely important that the operator uses adequate safety equipment and clothing, such as:

- Leather welding gauntlets (part no 8133492)
- Leather welding apron (part no 6000920)
- Safety shoes
- Safety mask (or even better, a helmet) large enough to cover the whole of the face, equipped with safety lenses able to filter all the radiation and reduce the intensity of the light absorbed by the eye.
- Safety screens should be installed around the work area to protect other people who may be working nearby, from the radiation given out by the arc.

---

## **THE WORK AREA**













---

The work area should be clean and well lit. Bystanders etc should be kept away to prevent injury or distraction.

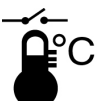
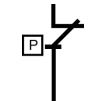
Arrange the power cable along a safe route so as to avoid a trip hazard. Allow enough range of movement to facilitate movement while working keeping the cutter within 2 metres of the workpiece to be cut.

- A barrier such as a welding curtain or screen e.g. CLARKE Welding Screen (part no 6000945) should be put up to protect others from flashing and sparks.

## SAFETY SYMBOLS

	Read Instruction manual before use		Flammable
	Caution - The user should be aware of a general hazard		Hot Surface - Do not touch
	Dangerous voltage		Poisonous fumes - Do not use in an enclosed space.
	Plasma cutting		Thermal protection devices
	Under pressure protection device		Wear protective gloves
	Wear a dust mask		Use a protective eyewear
	Appliance for indoor use only		This appliance falls under the WEEE Directive for disposal of waste electrical equipment.

# ELECTRICAL CONNECTIONS



**WARNING! READ THESE ELECTRICAL SAFETY INSTRUCTIONS THOROUGHLY BEFORE CONNECTING THE PRODUCT TO THE MAINS SUPPLY.**

Before switching the product on, make sure that the voltage of your electricity supply is the same as that indicated on the rating plate. This product is designed to operate on 230VAC 50Hz. Connecting it to any other power source may cause damage.

This product may be fitted with a non-rewireable plug. If it is necessary to change the fuse in the plug, the fuse cover must be refitted. If the fuse cover becomes lost or damaged, the plug must not be used until a suitable replacement is obtained.

If the plug has to be changed because it is not suitable for your socket, or due to damage, it should be cut off and a replacement fitted, following the wiring instructions shown below. The old plug must be disposed of safely, as insertion into a mains socket could cause an electrical hazard.



**WARNING! THE WIRES IN THE POWER CABLE OF THIS PRODUCT ARE COLOURED IN ACCORDANCE WITH THE FOLLOWING CODE: BLUE = NEUTRAL BROWN = LIVE YELLOW AND GREEN = EARTH**

If the colours of the wires in the power cable of this product do not correspond with the markings on the terminals of your plug, proceed as follows.

- The **Blue** wire must be connected to the terminal marked **N** or coloured **Black**.
- The **Brown** wire must be connected to the terminal marked **L** or coloured **Red**.
- The **Yellow and Green** wire must be connected to the terminal marked **E** or  or coloured **Green**.

**Plug must be BS1363/A approved.**

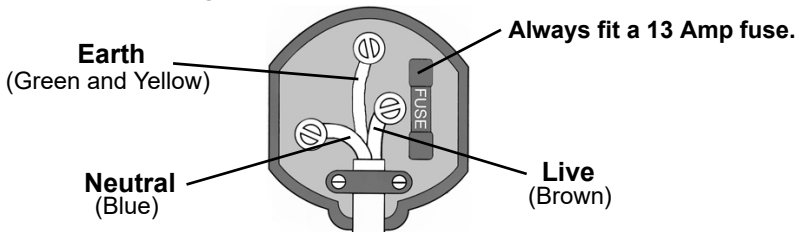

**Ensure that the outer sheath of the cable is firmly held by the clamp**

We strongly recommend that this machine is connected to the mains supply via a Residual Current Device (RCD). If in any doubt, consult a qualified electrician. DO NOT attempt any repairs yourself.

## COMPRESSED AIR REQUIREMENTS

A source of clean, dry compressed air or nitrogen must be supplied to your plasma cutting unit. An air regulator is incorporated into the unit. A male quick release adapter is used to connect the air supply hose to the filter/regulator.

- The operating pressure must be between 3 and 3.5 bar (0.3 and 0.35Mpa)
- The supply must also have a flow rate of approximately 7.2 cfm.

**Failure to operate within the limits could result in excessive operating temperatures or damage to the machine.**



**WARNING: COMPRESSED AIR CAN BE DANGEROUS. ENSURE THAT YOU ARE FAMILIAR WITH ALL PRECAUTIONS RELATING TO THE USE OF COMPRESSORS AND COMPRESSED AIR SUPPLY.**

### A TYPICAL AIR LINE LAYOUT IS SHOWN BELOW

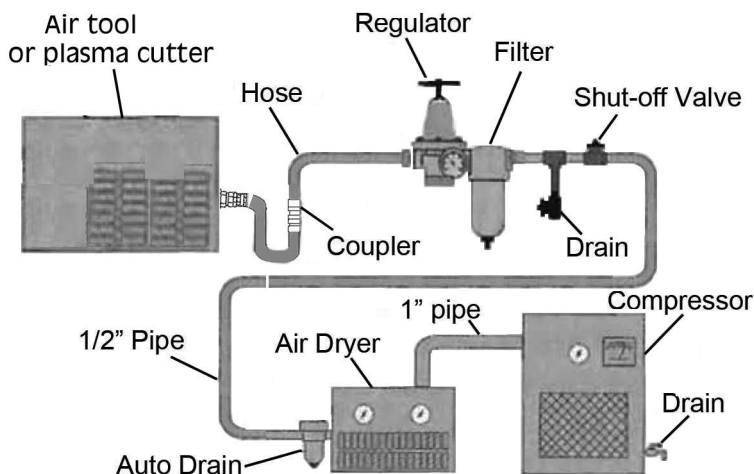

Never exceed the maximum operating pressure for the machine. It is recommended that air pressure to the plasma cutter does not exceed 90 psi at the machine. Higher pressures are a possible safety hazard.

Use only clean, dry, oil-free compressed air.

Air compressors used with the cutter must comply with the appropriate European Community Safety Directives.

A build-up of moisture in the air compressor will accelerate wear and corrosion in the machine. Ensure any moisture is drained from the compressor daily and the inlet filter is kept clean.



If an unusually long air hose is required, (over 8 metres), the line pressure or the hose inside diameter may need to be increased.

**NOTE:** The air hose must be rated at least 150% of the maximum operating pressure of the air tool or other machine.

---

## **PRINCIPLES OF OPERATION**

---

### **PRINCIPLES OF PLASMA CUTTING**

Plasma cutting is a fast, clean and distortion free, means of cutting through all types of metal from mild and stainless steels to aluminium, brass and copper.

- An inert gas (compressed air) is blown at high speed out of the nozzle; whilst at the same time an electrical arc travels through the gas, heating it to an extremely high temperature, which ionizes the gas.
- The column of heated ionized gas is called "Plasma" and is a good conductor of electricity.
- The cutting procedure utilises the plasma to transfer the electric arc to the metal workpiece, which is melted by the heat and then blown out of the way using the compressed air supply.

### **HOW THE PLASMA CUTTER WORKS**

- The process is created by an arc which is struck between the electrode (negative polarity) and the torch nozzle (positive polarity) due to the short circuit between these two elements.
- When the torch is brought into direct contact with the workpiece (connected to the positive polarity of the power source) the arc is transferred between the electrode and the workpiece itself, thus striking a plasma arc, also called cutting arc.

### **THERMAL PROTECTION DEVICE**

- This is installed at the points most subject to high temperatures such as the power transformers and the rectifying units. An amber light on the front panel lights up when the thermal protection device intervenes and the machine returns to service when it cools down.

# OVERVIEW AND CONTENTS

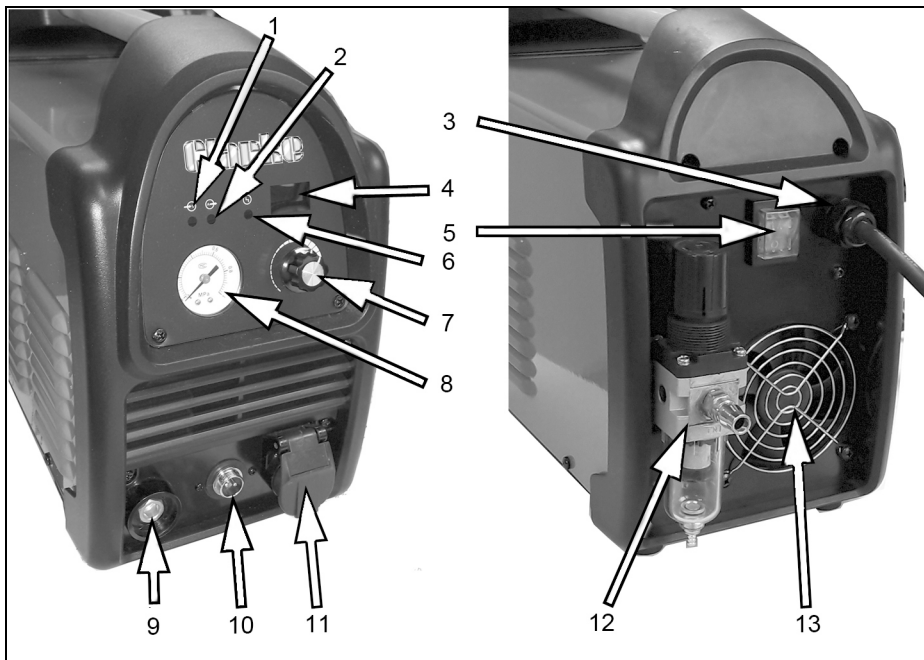

1	Green "Power On" LED	8	Air Pressure gauge
2	Red "Cutting in Progress" LED	9	Earth cable connection
3	Power supply cable	10	Torch (Trigger) connection
4	Digital power display (Amps)	11	Torch (Cutting nozzle) connection
5	On/Off switch	12	Compressed air filter/regulator
6	Yellow "Overheating" LED	13	Cooling Fan
7	Control Potentiometer		

## CONTENTS;

- 1 x Plasma Cutter
- 1 x Earth Lead
- 1 x Output power lead and torch
- 1 x Bag of consumable parts for the torch

## PREPARATION FOR USE

1. Connect the power supply cable to a mains socket.
2. Connect the earthing cable into the machine (push in and twist).
3. Connect the two screw-in connections to the cutting torch.

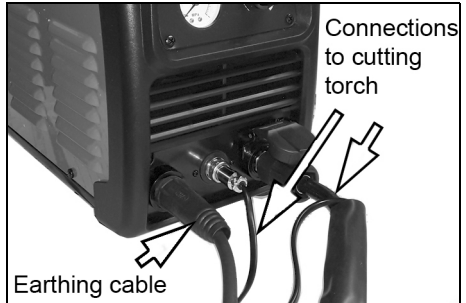

4. Connect the compressed air supply to the filter/regulator.
  - An adaptor is supplied to receive a length of hose.
5. Turn the air supply 'ON'.
6. Pull up the air regulator knob and turn it anticlockwise until a pressure of 0.3 - 0.35Mpa is displayed on the gauge.

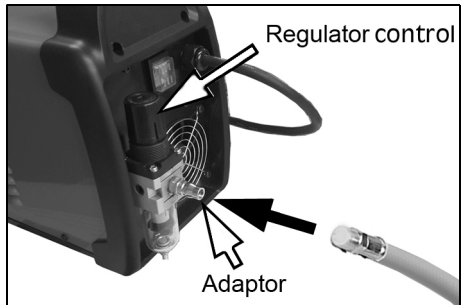

7. When the pressure is set, push the knob down to lock it at that setting.
8. Fasten the earth clamp to the workpiece. If a metal bench is being used, make sure it has also been connected to earth. Clamp as close as possible to the workpiece and take care not to damage the cable while cutting.

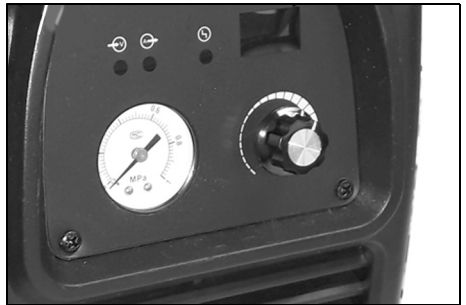

- If the surface of the workpiece is painted or rusty, clean the surface so that satisfactory contact between the workpiece and the earth clamp can be obtained.

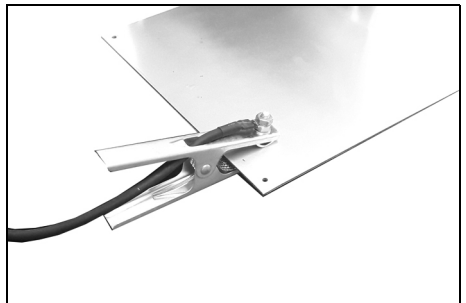

## USING THE PLASMA CUTTER

The torch can be comfortably held in one hand or steadied with two hands. Choose the technique that feels most comfortable and allows good control and movement. Position the index finger or thumb to depress the switch on the torch handle.

### SWITCHING ON/OFF

1. Switch the plasma cutter ON using the ON/OFF switch.
  - The green LED and the digital display will light up on the control panel.
  - After switching off the machine, the cooling fan will run briefly to cool the machine down.
2. Set the desired current (10-25 amps) for the type of metal being cut using the potentiometer knob. See cutting table on page 13.
  - Thin metals require lower current.
3. DO NOT touch the torch and cable with hot items.
4. DO NOT strain the cable.
5. DO NOT rest the cable across sharp edges or abrasive surfaces.
6. DO NOT step on the cable.

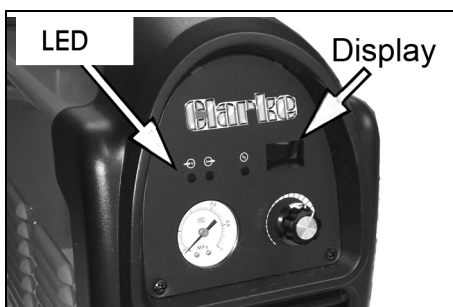
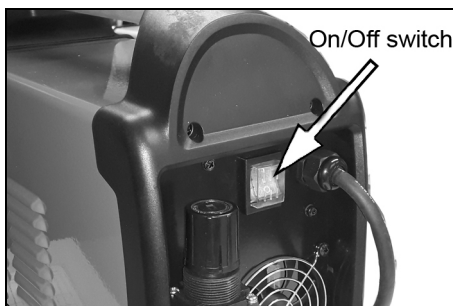

### CUTTING

1. Hold the torch firmly in the starting position squeeze the trigger switch.
  - The red "Cutting" LED will illuminate and the machine will initiate a gas purge (pre-flow) to remove any condensation that has accumulated in the torch.
  - If the cutting arc has not started after 2-3 seconds the trigger should be released and pressed again.
2. Once on, the cutting arc remains on as long as the trigger is held down unless the torch is withdrawn from the work or torch motion is too slow. Keep moving while cutting.

3. Move the cutting head more slowly for thicker and harder metals and keep the cutting head moving while cutting.
4. If clean cutting is not achieved, adjust the control potentiometer knob to a higher level and/or increase air flow.

## CUTTING TABLE

Thickness	Steel	Aluminium
1mm		16A clean cutting
2mm	15A clean cutting	20A clean cutting
3mm	20A clean cutting	25A clean cutting
4mm	25A clean cutting	25A severance cutting
5mm	20A severance cutting	
6mm	25A severance cutting	

### FOR EDGE STARTS

Hold the torch perpendicular to the workpiece with the front of the tip on the edge of the workpiece at the point where the cut is to start.

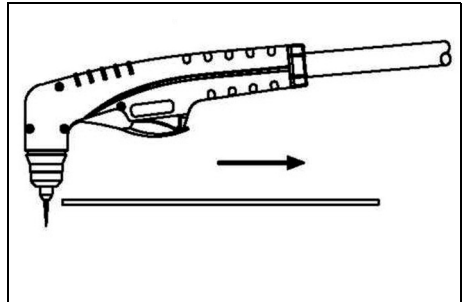

### FOR DRAG CUTS

Keep the torch in contact with the workpiece.

5. Cut at a steady speed without pausing. Maintain the cutting speed so that the arc is about 30° behind the direction of travel.
6. Keep the torch in light contact with the workpiece to avoid nuisance shut off of the torch.

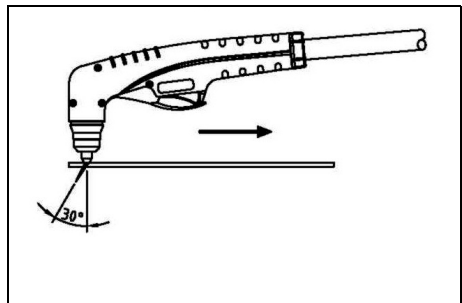

## PIERCING WITH THE TORCH

NOTE: The recommended maximum cutting capability from an edge is 2mm. If you need to cut sheet metal more than 2mm without an edge start, make a hole  $\varnothing$  6mm using an electric drill before you start cutting.

1. When piercing, tilt the torch so that blowback particles blow away from both the operator and the torch.

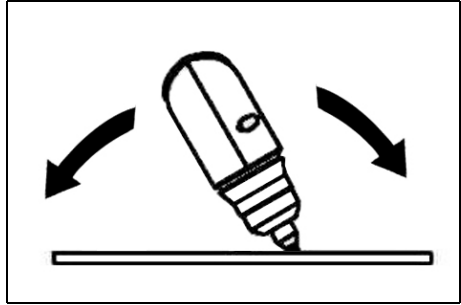

2. Complete the piercing off the cutting line and then continue the cut onto the line. Hold the torch perpendicular to the workpiece after the cut is complete.

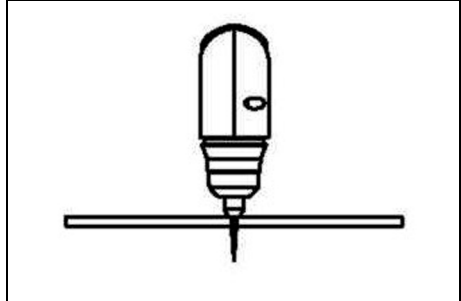

3. Clean spatter and scale from the shield cup and the tip as soon as possible. Spraying or dipping the shield cup in anti-spatter compound will minimize the scale which adheres to it.



CAUTION: SPARKS FROM THE CUTTING PROCESS CAN CAUSE DAMAGE TO COATED, PAINTED AND OTHER SURFACES SUCH AS GLASS, PLASTIC AND METAL.

4. Handle torch leads with care and protect them from damage.

## SHUTTING OFF THE PLASMA CUTTER

1. To stop cutting, remove the torch from the workpiece and release the trigger.

**NOTE:** When the trigger is released, compressed air will continue to flow for a short period of time in order to cool the torch. DO NOT switch off the machine until the air has stopped flowing or damage may occur to the torch.

2. When finished cutting and the airflow has stopped switch the cutter off and turn off the air supply.

# TROUBLESHOOTING

Problem	Possible Cause and Likely solution	
Machine does not function when switched on.	Tripped thermal protection device.	Allow the machine to cool until the yellow "Overheating" LED goes off, then resume use. Reduce duration of cutting periods to help reduce load on the machine and tendency to overheat.
	Internal fuse blown.	Return to your CLARKE dealer for investigation.
	Faulty power switch	Return to your CLARKE dealer for investigation.
Cutting not stable	Loose torch cable or earth clamp cable.	Check that all connections are tight.
	Damaged torch connection within torch.	Return to your CLARKE dealer for investigation.
Weak arc strength	Incorrect line voltage.	Have a qualified electrician investigate the situation.
Arc does not ignite	Poor ground connection.	Make certain that the work piece has a good connection with the earth clamp using a clean surface at the contact location.
	Incorrectly sized or excessively worn nozzle.	Confirm that the nozzle is the correct size for the torch used. Check that the hole in the tip is not deformed, enlarged or dirty. Replace if required.

<b>Problem</b>	<b>Possible Cause and Likely solution</b>	
Gas does not flow	Nozzle blocked.	Clean nozzle and replace if necessary.
	Air pressure regulator not sufficiently open.	Ensure regulator is correctly adjusted.
	Blockage in compressed airline	Check supply hose and the hose within the cutting torch cable.
Unit continually overheats	Input voltage too high or too low.	Have electrician inspect the building power supply.
Insufficient penetration	<ol style="list-style-type: none"> <li>1. Cutting speed too high.</li> <li>2. Torch is tilted.</li> <li>3. Workpiece is too thick.</li> <li>4. Cutting current is too low.</li> <li>5. Torch parts are worn out.</li> </ol>	
Interruption of the cutting arc	<ol style="list-style-type: none"> <li>1. Cutting speed too slow</li> <li>2. Excessive distance between torch and workpiece</li> <li>3. AC line too low - reduce output current</li> <li>4. Torch parts are worn out</li> <li>5. Non-genuine manufacturer's parts</li> <li>6. Work cable is disconnected</li> </ol>	
Excessive scoria settlement	<ol style="list-style-type: none"> <li>1. Too low cutting speed causing bottom dross</li> <li>2. Too high cutting speed causing top dross</li> <li>3. Excessive distance between torch and workpiece.</li> <li>4. Cutting current too low</li> <li>5. Torch parts are worn out</li> <li>6. Non-genuine manufacturer's parts</li> </ol>	
Tilted cutting	<ol style="list-style-type: none"> <li>1. Torch position not correct</li> <li>2. Asymmetric wear of nozzle hole and/or wrong assembly of the torch parts</li> </ol>	



Problem	Possible Cause and Likely solution
Excessive wear of the nozzle and electrodes	<ol style="list-style-type: none"> <li>1. Air pressure too low</li> <li>2. Exceeding system capability (material too thick)</li> <li>3. Contaminated air (humidity-oil)</li> <li>4. Improperly assembled torch</li> <li>5. Torch tip contacting workpiece</li> <li>6. Damaged or loose torch head components</li> <li>7. Non-genuine manufacturer's parts</li> </ol>

## DATA PLATE INFORMATION



Imported by  
**Clarke INTERNATIONAL**  
EPPING, ESSEX CM116 4LG ENGLAND

Single phase static frequency converter transformer rectifier → IDENTIFICATION	<b>Model No: PLASMA KING 25Si</b> <b>Part No: 6015700</b>	<b>Serial No:</b>	<b>Batch No:</b>			
		<b>EN60974-1:2012 EN60974-10:2014</b>		<b>15A/86V TO 25A/90V</b>		
Welding power source → OUTPUT			<b>X</b>	<b>30%</b>	<b>60%</b>	<b>100%</b>
Input supply → ENERGY INPUT		$U_0 = 400V$	$I_2$	<b>25A</b>	<b>20A</b>	<b>15A</b>
Ingress protection → ENERGY INPUT		$U_1 = 230V$	$I_{1MAX} = 20A$	$I_{1EFF} = 11A$		
	<b>IP21S</b>					

---

# MAINTENANCE

---



CAUTION: BEFORE PERFORMING ANY MAINTENANCE ON THE PLASMA CUTTER TURN OFF AT THE MAINS SOCKET AND LET ALL PARTS COOL DOWN.

---

DO NOT open or dismantle the machine. Repairs must only be undertaken by your CLARKE dealer.

Keep the machine clean by wiping with a soft cloth. DO NOT use abrasives.

Check that cables and leads are in good condition. If damaged, contact your authorised service agent. Keep cables and leads clean. DO NOT use solvents.

## TORCH AND CABLE

These parts need no maintenance with the exception of a periodic inspection and cleaning. All repairs should be carried out by a qualified service engineer.

- DO NOT use solvents or strong detergents when cleaning.
- If there is damage to the insulation such as breaks, cracks and burns or even a loosening of electric conductors, the torch must not be used.

Manually dismantle the torch nozzle head.

To replace the consumable parts in the torch:

1. Unscrew the shield cup from the torch head assembly.
  - Clean the shield cup thoroughly and replace if it is damaged (burns, distortions or cracks). If in any doubt, replace.
2. Remove the nozzle, gas diffuser ring and electrode.
3. Fit a new nozzle, gas diffuser ring and electrode.
  - ALWAYS replace the nozzle, gas diffuser ring and electrode at the same time.
4. Replace the shield cup and ensure that it is secure.

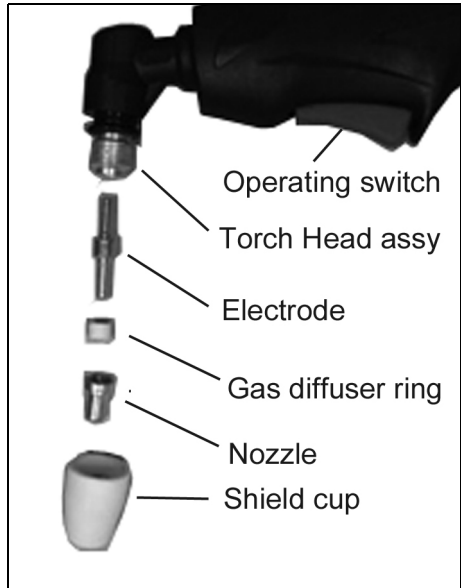

- Check the build-up on the emitting surface of the electrode. When the build-up is approximately 2mm replace the electrode.
  - Check that the diffuser ring is not burned or cracked and that the airflow holes are not obstructed. If damaged replace.
5. If the nozzle surface is oxidised, clean with extra fine abrasive paper. Check wear of the plasma arc hole and the inner and outer surfaces. If the hole has widened, or the nozzle is damaged in any way, replace it. The nozzle "V" crater should be 1.5mm in depth.

## **COMPRESSED AIR FILTER**

The unit is equipped with a filter for the compressed air which captures water and oil vapour. The filter is fitted with a plunger for the manual draining of the condensation. Periodically drain the water in the filter.

The air filter and air filter cartridge can only be replaced by a qualified service engineer. Contact your nearest CLARKE service department.

## **STORAGE AND HANDLING**

Store the machine in a dry location free from damp and humidity. Always carry the machine by its handle and avoid straining the power cable, earth cable or torch connector.

## SPECIFICATIONS

<b>PLASMA KING 25si</b>	<b>Part No 6015700</b>
Power supply	230V-50Hz-1Ph
Input Current (MAX)	20A
Output current (MIN-MAX)	15A - 25A
Ingress protection Class	IP21S
Compressed air pressure	0.3 - 0.35 Mpa
Compressed air flow rate	7.2 cfm
Duty cycle	30% @ 25 Amps 60% @ 20 Amps 100% @ 15 Amps
Weight	9.25 kg
Dimensions L x W x H	440 x 175 x 290 mm
Maximum cutting depth	Steel - 4mm clean cut 6 mm rough severance  Aluminium - 3 mm clean cut 4 mm rough severance

Please note that the details and specifications contained within, are correct at the time of going to print. However, CLARKE International reserve the right to change specifications at any time without prior notice.

# DECLARATIONS OF CONFORMITY



**Clarke**<sup>®</sup>  
INTERNATIONAL  
Fitzwilliam Hall, Fitzwilliam Place, Dublin 2

## DECLARATION OF CONFORMITY

This is an important document and should be retained.

We hereby declare that this product(s) complies with the following directive(s):

- 2014/30/EU Electromagnetic Compatibility Directive.
- 2014/35/EU Low Voltage Equipment Directive.
- 2011/65/EU Restriction of Hazardous Substances (Amendment EU 2015/863).

The following standards have been applied to the product(s):

- EN 60974-10:2014+A1:2015, EN 60974-1:2012, EN 62321-2:2014, EN 62321-3-1:2014,
- EN 62321-4-2014+A1:2017, EN 62321-5:2014, EN 62321-7-1:2015, EN 62321-7-2:2017,
- EN 62321-8:2015, EN 62321-8:2017.

The technical documentation required to demonstrate that the product(s) meet(s) the requirement(s) of the aforementioned directive(s) has been compiled and is available for inspection by the relevant enforcement authorities.

The CE mark was first applied in: 2021

**Product Description:** 25A Plasma Cutter  
**Model number(s):** Plasma King 25SI  
**Serial / batch Number:** N/A  
**Date of issue:** 18/11/2021

J.A. Clarke  
Director



**Clarke**<sup>®</sup>  
INTERNATIONAL  
Hemond Street, Epping, Essex, CM16 4LG

## DECLARATION OF CONFORMITY

This is an important document and should be retained.

We hereby declare that this product(s) complies with the following statutory requirements(s):

- Electromagnetic Compatibility Regulations 2016
- Electrical Equipment (Safety) Regulations 2016
- The Restriction of the Use of Certain Hazardous Substances in Electrical and Electronic Equipment Regulations 2012

The following standards have been applied to the product(s):

- EN 60974-10:2014+A1:2015, EN 60974-1:2012, EN 62321-2:2014, EN 62321-3-1:2014,
- EN 62321-4-2014+A1:2017, EN 62321-5:2014, EN 62321-7-1:2015, EN 62321-7-2:2017,
- EN 62321-8:2015, EN 62321-8:2017.

The technical documentation required to demonstrate that the product(s) meet(s) the requirement(s) of the aforementioned legislation has been compiled and is available for inspection by the relevant enforcement authorities.

The UKCA mark was first applied in: 2021

**Product Description:** 25A Plasma Cutter  
**Model number(s):** Plasma King 25SI  
**Serial / batch Number:** N/A  
**Date of issue:** 18/11/2021

J.A. Clarke  
Director

# COMPONENT PARTS

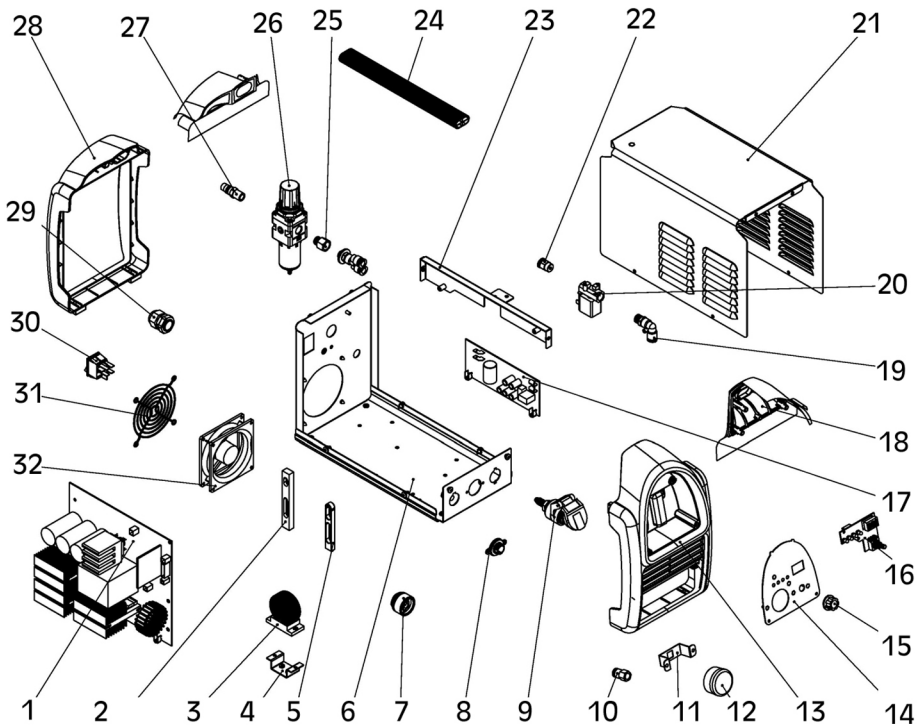

## COMPONENT PARTS

No	DESCRIPTION
1	Main PCB
2	IGBT Radiator support bar
3	Inductor
4	Inductor bracket
5	Rectifier support bar
6	Bottom panel
7	Quick connector
8	Torch connection
9	Torch connector socket
10	Air interface
11	Barometer bracket
12	Barometer
13	Plastic front cover
14	Control panel
15	Knob
16	Control panel PCB

No	DESCRIPTION
17	Arc ignition PCB
18	Plastic cover
19	Air connector
20	Solenoid valve
21	Top housing
22	Air connector
23	Support beam
24	Handle
25	Air connector
26	Pressure reducing valve
27	Air connector
28	Plastic back cover
29	Cable clip
30	On/Off switch
31	Fan hood
32	DC Fan

# A SELECTION FROM THE VAST RANGE OF

# Clarke®

## QUALITY PRODUCTS



**AIR COMPRESSORS**  
From DIY to industrial, Plus air tools, spray guns and accessories.

**GENERATORS**  
Prime duty or emergency standby for business, home and leisure.

**POWER WASHERS**  
Hot and cold, electric and engine driven - we have what you need

**WELDERS**  
Mig, Arc, Tig and Spot. From DIY to auto/industrial.

**METALWORKING**  
Drills, grinders and saws for DIY and professional use.

**WOODWORKING**  
Saws, sanders, lathes, mortisers and dust extraction.

**HYDRAULICS**  
Cranes, body repair kits, transmission jacks for all types of workshop use.

**WATER PUMPS**  
Submersible, electric and engine driven for DIY, agriculture and industry.

**POWERTOOLS**  
Angle grinders, cordless drill sets, saws and sanders.

**STARTERS/CHARGERS**  
All sizes for car and commercial use.



## PARTS & SERVICE: 0208 988 7400

**Parts Enquiries**  
[Parts@clarkeinternational.com](mailto:Parts@clarkeinternational.com)

**Servicing & Technical Enquiries**  
[Service@clarkeinternational.com](mailto:Service@clarkeinternational.com)

SALES: UK 01992 565333 or Export 00 44 (0)1992 565335

**Clarke®** INTERNATIONAL Hemnall Street, Epping, Essex CM16 4LG  
[www.clarkeinternational.com](http://www.clarkeinternational.com)