

A SELECTION FROM THE VAST RANGE OF

ClarkeTM

QUALITY PRODUCTS



AIR COMPRESSORS

From DIY to industrial. Plus air tools, spray guns and accessories.

GENERATORS

Prime duty or emergency standby for business, home and leisure.

POWER WASHERS

Hot and cold, electric and engine driven - we have what you need.

WELDERS

Mig, Arc, Tig and Spot. From DIY to auto/industrial.

METALWORKING

Drills, grinders and saws for DIY and professional use.

WOODWORKING

Saws, sanders, lathes, mortisers and dust extraction.

HYDRAULICS

Cranes, body repair kits, transmission jacks for all types of workshop use.

WATER PUMPS

Submersible, electric and engine driven for DIY, agriculture and industry.

POWER TOOLS

Angle grinders, cordless drill sets, saws and sanders.

STARTER/CHARGERS

All sizes for car & commercial use.

ClarkeTM

air



SPOT BLAST GUN

MODEL NO: SB3

PART No: 5091101

Clarke INTERNATIONAL

For spare parts and servicing, please contact your nearest dealer, or Clarke International on

020 - 8988 - 7400

e-mail: Parts@clarkeinternational.com e-mail: Service@clarkeinternational.com

OPERATION & MAINTENANCE INSTRUCTIONS



SPECIFICATIONS

Model :	SB3
Part No :	5091101
Cup Capacity :	1 Litre
Air Consumption :	20 cfm
Air Inlet Connector :	¼" BSP
Nozzle :	6 mm
Operating Pressure :	5.5-6.5bar

Please note that the details and specifications contained herein are correct at the time of going to print. However CLARKE International reserve the right to change specifications at any time without prior notice.

PARTS LIST

No	DESCRIPTION	PART NUMBER	Qty
1	Main Body	NSSB301	1
2	Container Cap complete	NSSB302	1
3	Container	NSSB303	1
4	Nozzle	NSSB304	1
4a	Inner Nozzle	NSSB304a	1
5	Retaining Ring	NSSB305	1
6	Hose Tail 8mm	NSSB306	1
7	Nut 1/4" BSP	NSSB307	1
8	Air Valve Nut	NSSB308	1
9	Air Valve	NSSB309	1
10	Valve Needle	NSSB310	1
11	Valve Spring	NSSB311	1
12	Circlip	NSSB312	1
13	Trigger	NSSB313	1
14	Pivot Pin	NSSB314	1
15	O-Ring Large	NSSB315	1
16	O-Ring Small	NSSB316	1

For Al Oxide grit and Glass beads...see your CLARKE dealer

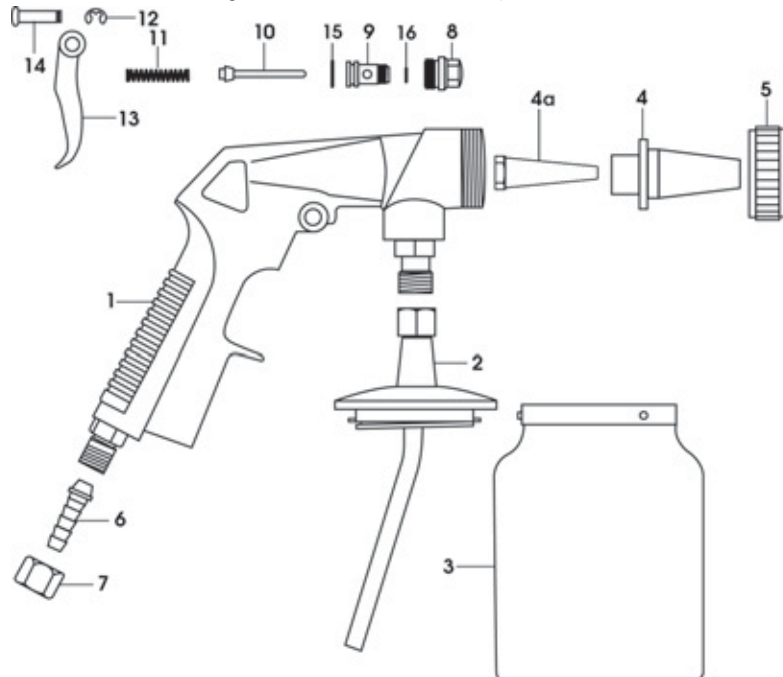

Please read these instructions carefully before operating the tool

Thank you for purchasing this **CLARKE** Spot Blast gun. Before using the device, please read this manual thoroughly and carefully follow all instructions given. This is for your own safety and that of others around you, and is also to help you achieve long and trouble free service from your new spray gun.

CLARKE GUARANTEE

This CLARKE product is guaranteed against faulty manufacture for a period of 12 months from the date of purchase. Please keep your receipt as proof of purchase.

This guarantee is invalid if the product is found to have been abused or tampered with in any way, or not used for the purpose for which it was intended.

Faulty goods should be returned to their place of purchase, no product can be returned to us without prior permission.

This guarantee does not affect your statutory rights.

Please be aware that certain parts of this spot blast gun will wear, requiring replacement and that these parts may not be covered by your guarantee.

The wear on certain parts depends on the abrasiveness of the materials used.

Replacement parts are available from your nearest Clarke International dealer.

PARTS & SERVICE TEL: 020 8988 7400

or e-mail as follows:

PARTS: Parts@clarkeinternational.com

SERVICE: Service@clarkeinternational.com

SAFETY PRECAUTIONS

⚠ WARNING ⚠

Compressed air can be dangerous. Ensure that you are thoroughly familiar with all precautions relating to the use of compressors and compressed air supply.



For your personal safety and that of others around you. Follow these safety instructions carefully.

NOTE : products used in this spray gun may be covered by COSHH Regulations.

- ✓ **ALWAYS** wear protective gloves and clothing, and a face shield or safety goggles.
NOTE: Spectacles DO NOT give sufficient protection, correct goggles must be worn, although a full face mask is strongly recommended.
- ✓ Dust masks **MUST ALWAYS BE WORN**. Inhaling dust produced by the spot blasting process or the possible inhalation or ingestion of grit is extremely hazardous.
- ✓ **ALWAYS** make sure there is adequate ventilation. Do not spray in confined or enclosed areas.
- ✓ **ALWAYS** disconnect the gun from the air supply when it is not in use, and before any disassembly.
- ✓ **ALWAYS** thoroughly clean the gun after use. See 'Maintenance'
- ✓ **ALWAYS** turn OFF the air supply at the compressor outlet, and expel all air from the air hose and gun, **BEFORE** disconnecting the Spot Blast Gun from the air hose.
- ✓ **ALWAYS** use appropriate air hoses and couplings and ensure that they are in good condition. If any parts are worn or damaged, they should be replaced immediately.
- ✓ **ALWAYS** hold the tool firmly and maintain good balance.
- ✓ **ALWAYS** ensure hose couplings are secure before use.
- ✗ **NEVER** carry the gun by the hose. Keep hoses away from heat, oil and sharp edges.
- ✗ **NEVER** use wet or even damp grit. Ensure the grit is completely dry.
- ✗ **NEVER** operate the gun in the vicinity of an air compressor unless an efficient air filter is fitted. The possibility of grit entering the air compressor cylinder, which would cause serious damage, should not be overlooked.
- ✗ **NEVER** direct the Grit Spray at people or animals.. In the case of injury, seek expert medical advice immediately.
- ✗ **NEVER** allow children to use or play with this appliance.
- ✗ **NEVER** operate the gun at pressures exceeding 100 psi (6.5 bar)

INSTALLATION

1. Connect your Spot Blast Gun to a regulated, dry air supply via the ¼" BSP connector at the base of the handle.
2. The pressure required to operate the gun is determined by the grit size and the finish required e.g.
High Pressure + Coarse Grit = Coarse Finish
Low Pressure + Fine Grit = Fine Finish
3. Fill the metal grit container with the appropriate grade of grit for dry blasting, as required.
NOTE: ALWAYS consult the grit manufacturers recommendations for the correct grade of grit to be used, and NEVER use wet or damp grit.
4. Fix the grit container to the gun via the bayonet fitting.

OPERATION

1. Ensure the breather hole in the container cap is clear.
2. Place the nozzle against a scrap piece of material, and pull the trigger to discharge excessive grit in the feed tube. You could cause damage to the workpiece if you do not carry out this procedure.
3. Hold gun the appropriate distance from the workpiece to be cleaned, (dependent upon the type of material and the size of grit being used), and where possible, perpendicular to the workpiece. Pull the trigger for a few seconds at a time. Check the workpiece frequently.
NOTE: The softer the material the lower the pressure, or the further the gun should be held from the workpiece.
4. Shake the gun frequently when in use, to prevent a cavity forming in the grit container, thereby ensuring that the grit will be drawn up correctly.

The finish left by the spot blast operation should be ideal for immediate priming where required.

MAINTENANCE (Numbers in brackets refer to item nos. in parts list)

WARNING

Disconnect the spray gun from the air supply, and relieve any pressure in the gun and hose, before any disassembly.

This Spot Blast Gun requires minimum maintenance, and requires no adjustment, as the Air/Grit mix is factory set. The nozzle is made of hardened steel for long life, but will need replacing from time to time, as indicated by a decrease in performance.

When not in use, remove the grit container, (3) via its bayonet fitting, the nozzle, (4) by unscrewing the retaining ring, and clean them thoroughly. Wipe all surfaces clean and dry ensuring that there are no traces of grit or waste material. Store in a dry environment.

Check the air valve on a monthly basis if the gun is used frequently, to ensure it moves smoothly and effectively. To do this, remove the circlip (12), securing the trigger pivot pin (14), then remove the pin (3) and the trigger.

Unscrew and remove the air valve. Ensure the sealing rings are perfectly serviceable. If in doubt, they should be replaced. Should there be an air leak, suspect the nylon seal on the valve needle (10).

When satisfied that all parts are serviceable, apply a thin coat of grease to the o-rings and reassemble.